

CLIENT
David Kuykendall

PROJECT
Ammo Can
Storage Rack

PROJECT NO.
2017.1

DRAWN BY
DK

ISSUE
1/31/2017

Isometric Perspective View

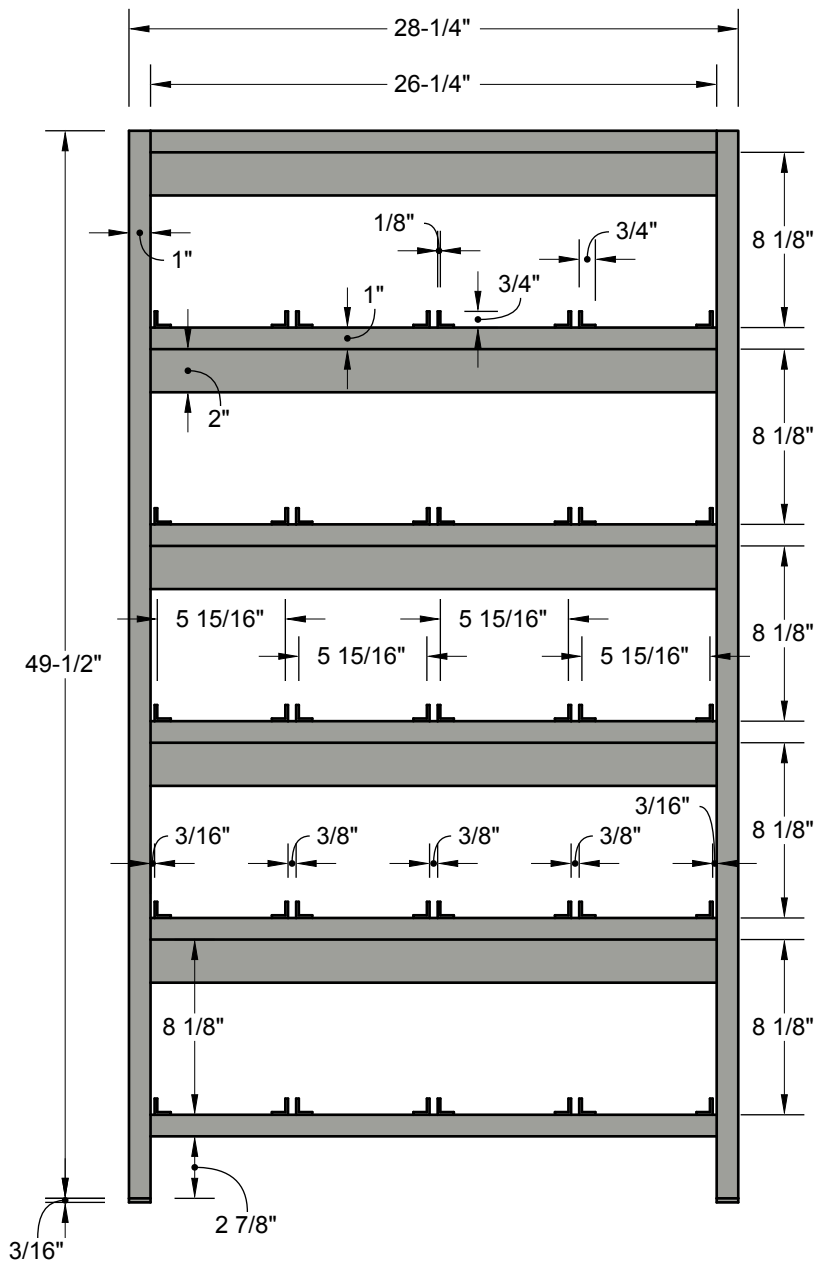
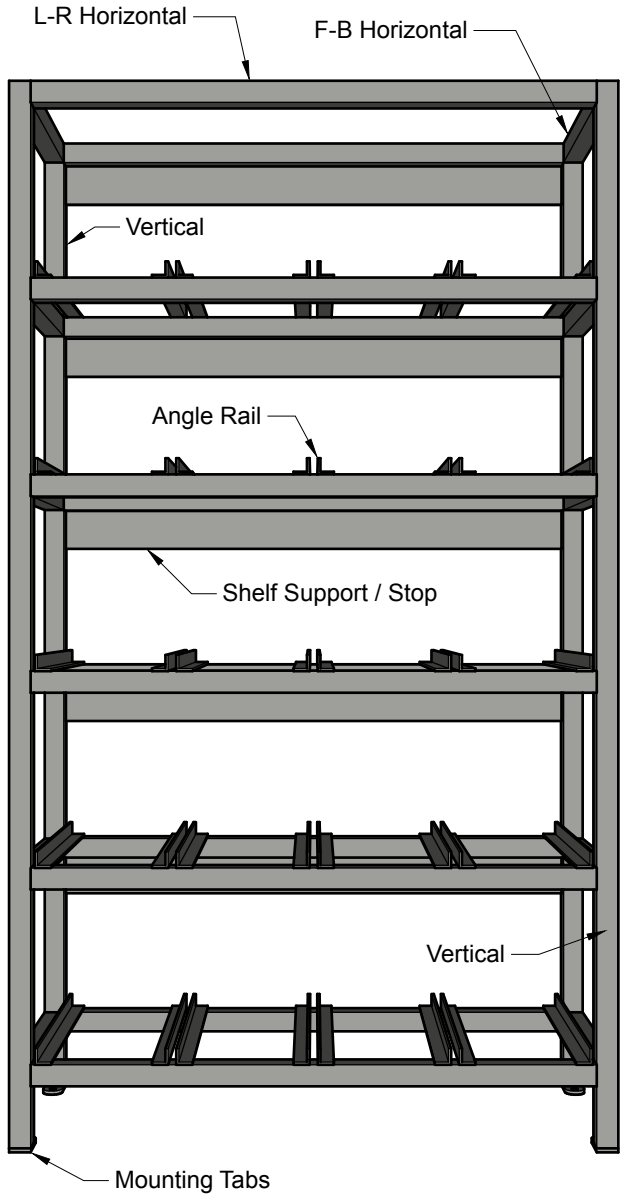

CLIENT
David Kuykendall
Conroe, Texas

PROJECT
Ammo Can
Storage Rack
PROJECT NO.
2017.1

ISSUE
1/31/2017
DRAWN BY
DK

Front View

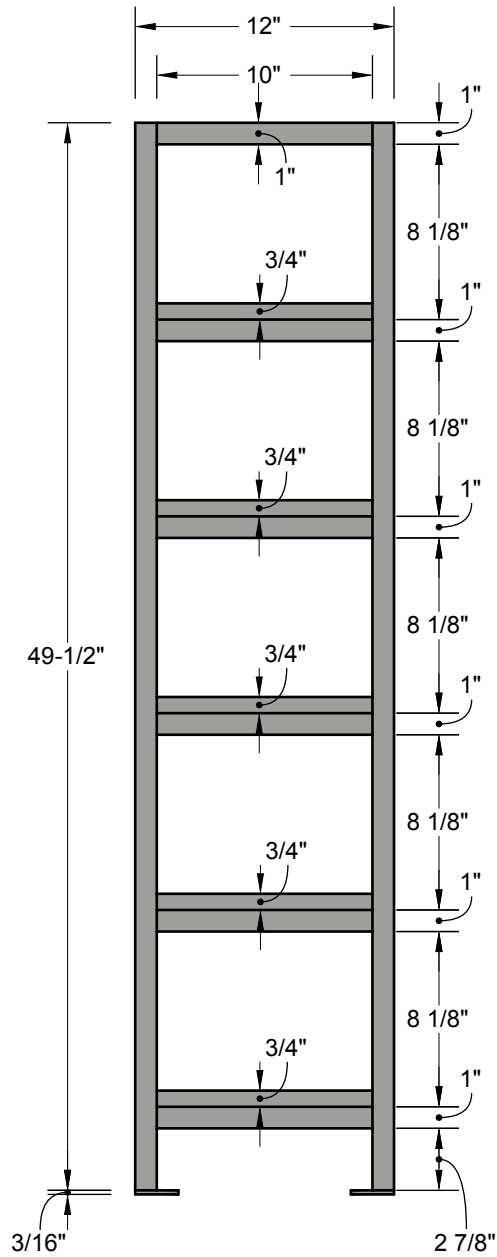
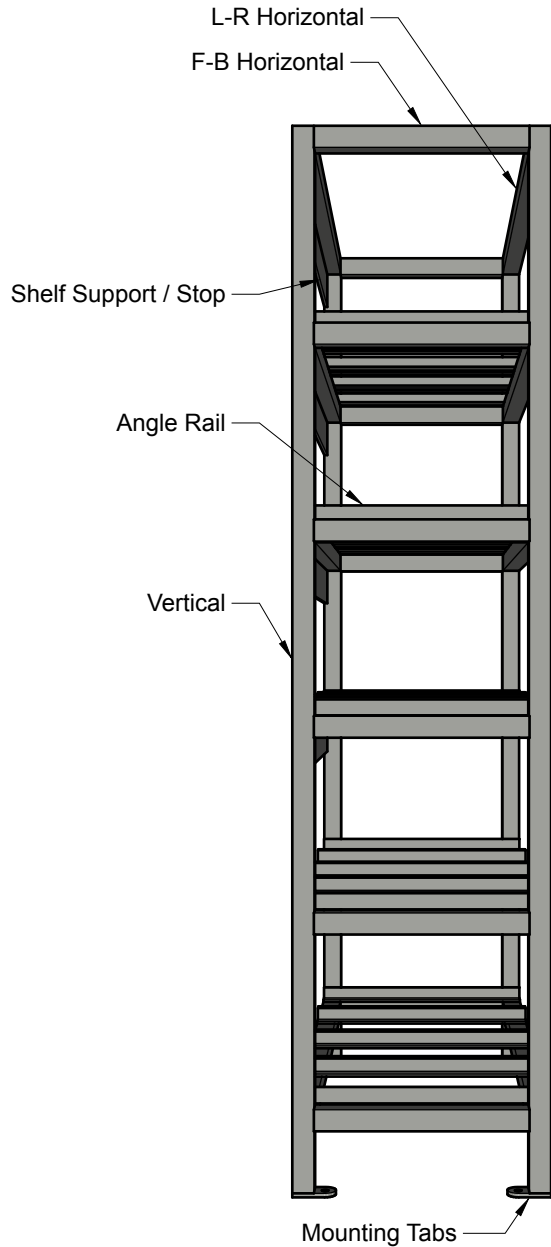

CLIENT
David Kuykendall
Conroe, Texas

PROJECT
Ammo Can
Storage Rack

ISSUE
1/31/2017

DRAWN BY
DK
PROJECT NO.
2017.1

Side View

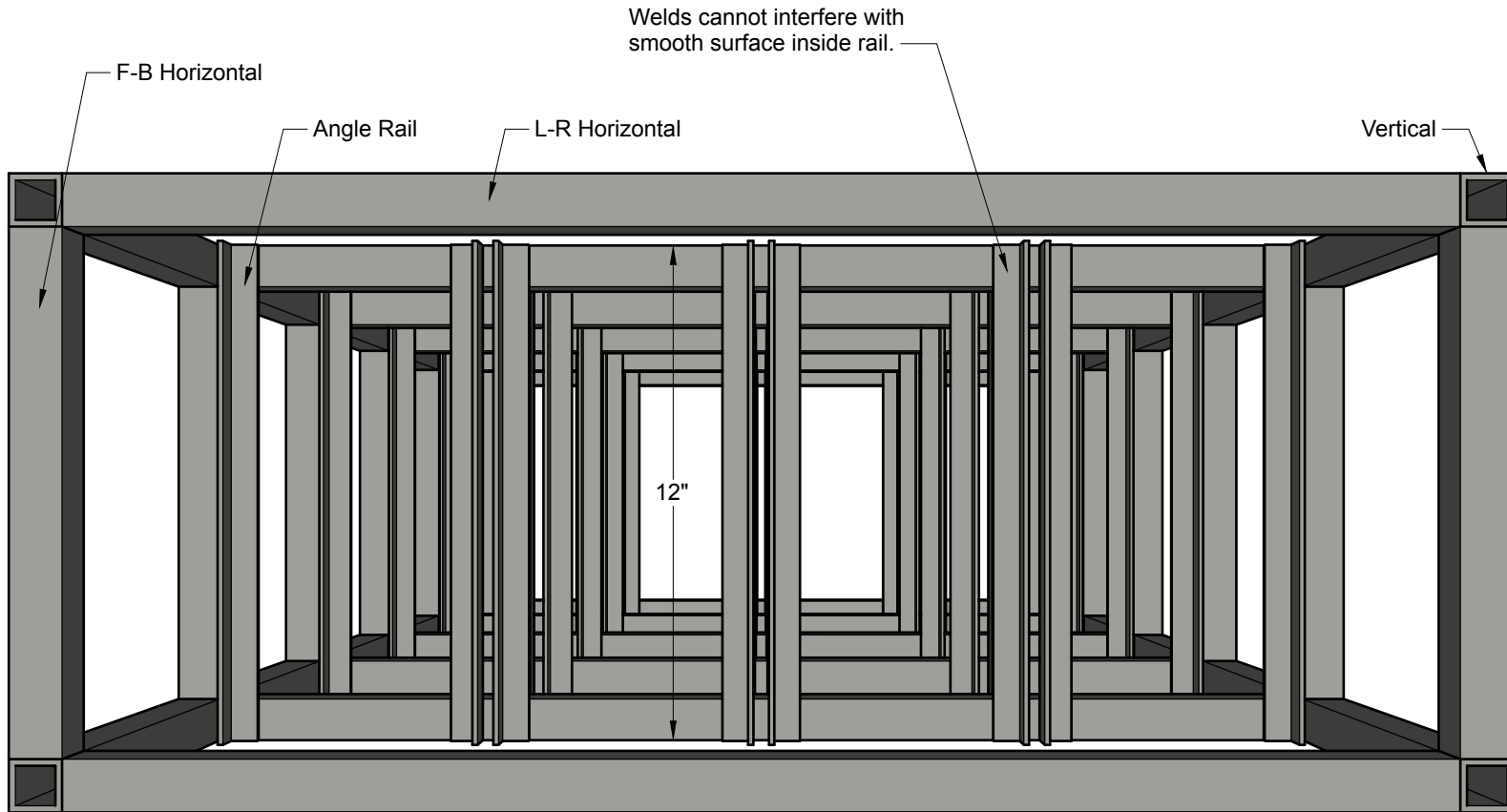

CLIENT
David Kuykendall
Conroe, Texas

PROJECT
Ammo Can
Storage Rack

PROJECT NO.
2017.1

ISSUE
1/31/2017

DRAWN BY
DK

Top View

A.03

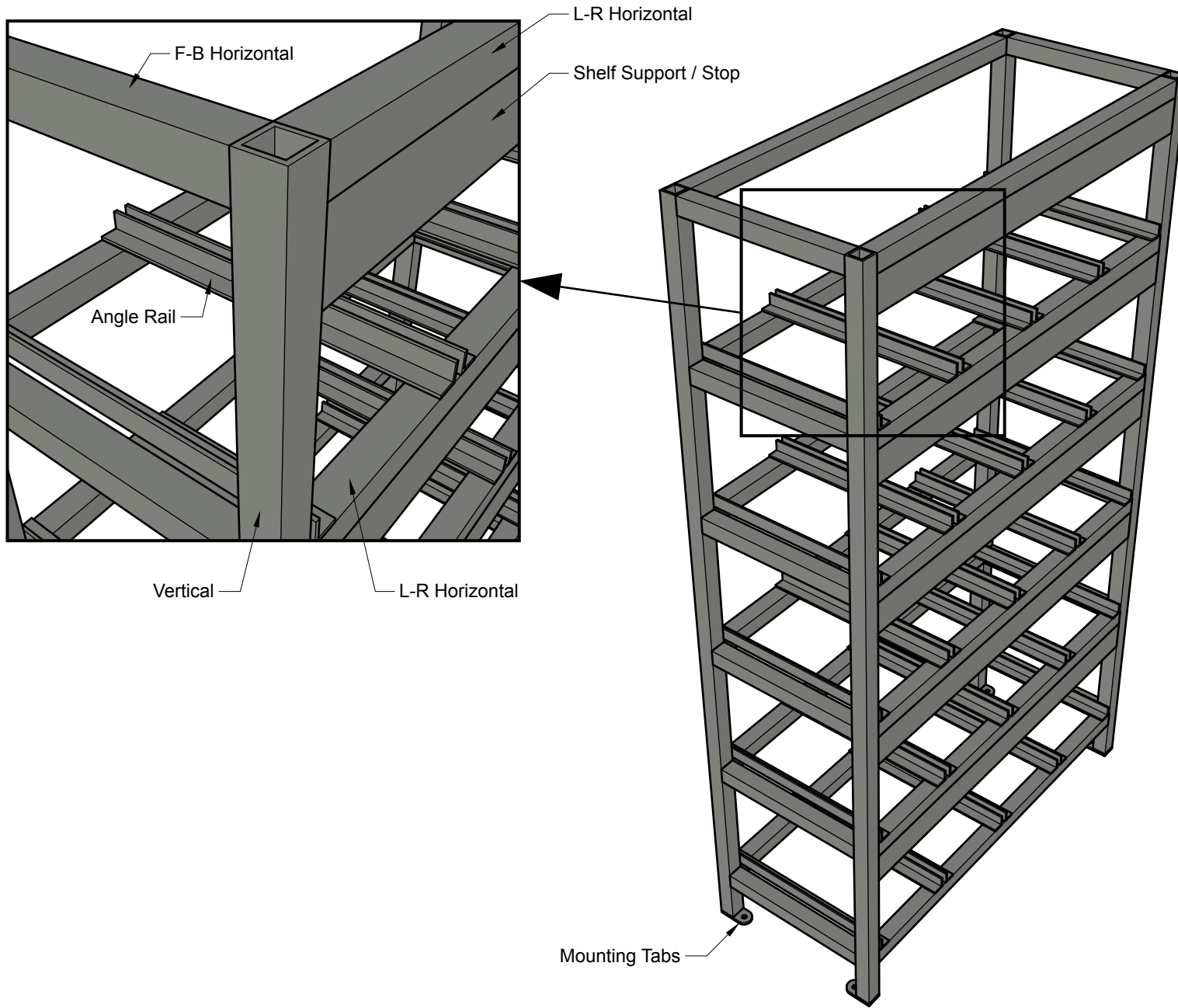

CLIENT
David Kuykendall
Conroe, Texas

PROJECT
Ammo Can
Storage Rack
PROJECT NO.
2017.1

ISSUE
1/31/2017
DRAWN BY
DK

**Rear View
with Detail**

A.04

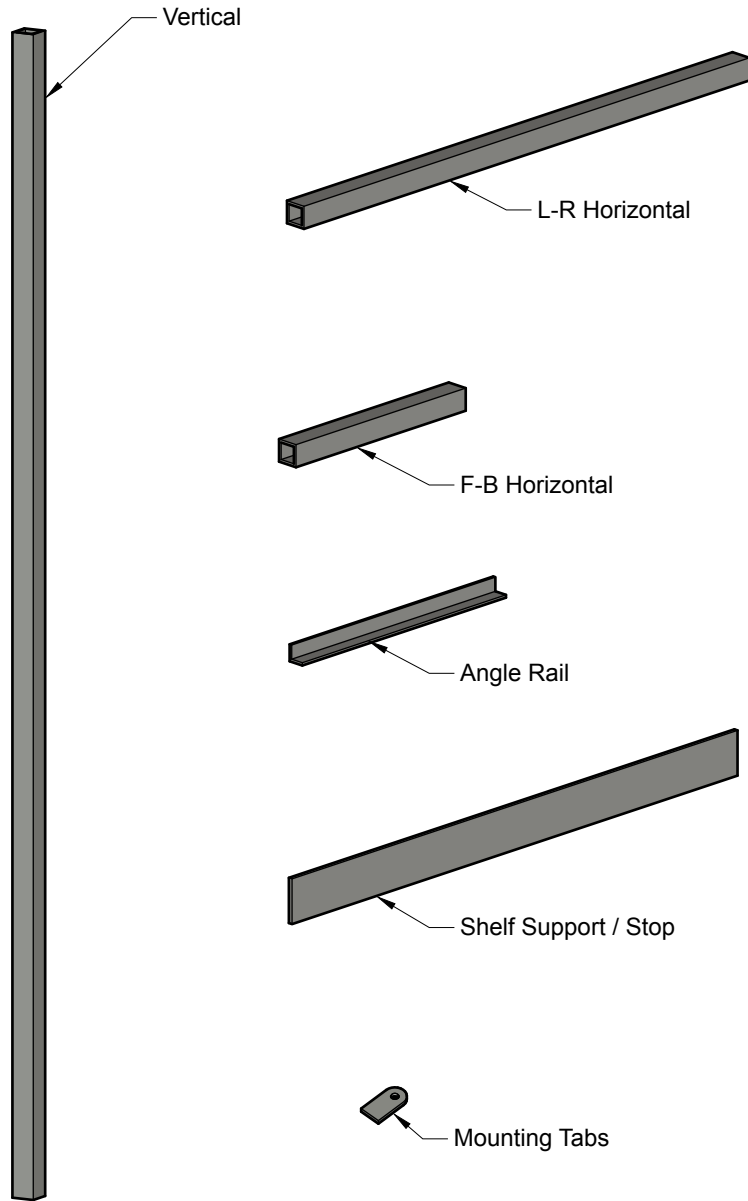

Quantity	Part Name	Description
4	Vertical	1" x 1" x 49-1/2" square tubing; 1/8" thick wall (minimum)
12	L-R Horizontal	1" x 1" x 26-1/4" square tubing; 1/8" thick wall (minimum)
12	F-B Horizontal	1" x 1" x 10" square tubing; 1/8" thick wall (minimum)
40	Angle Rail	3/4" x 3/4" x 12" angle stock; 1/8" thick (minimum)
5	Shelf Support / Stop	2" x 26-1/4"; 3/16" thick (minimum)
4	Mounting Tabs	1" x 2"; 3/16" thick (minimum); see detail on this page below

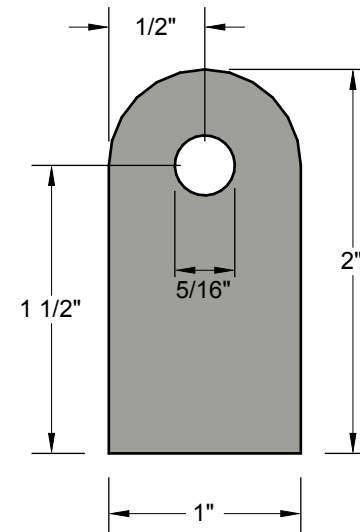

Mounting Tab Detail

CLIENT
David Kuykendall
Conroe, Texas

PROJECT
Ammo Can
Storage Rack

ISSUE
1/31/2017

DRAWN BY
DK
PROJECT NO.
2017.1

Parts List